

RV5-10 - Relief Valve

Spool, pilot operated

114 L/min (30 USgpm) • 350 bar (5000 psi)

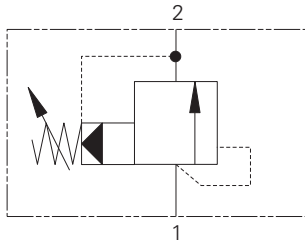

Operation

When the inlet pressure exceeds the setting of the valve, the pilot section opens, causing a small flow across the orifice in the main spool.

The subsequent pressure drop moves the spool against a light spring opening a ring of radial holes in the sleeve, allowing relief flow to tank.

Features

High accuracy of pilot operated design. Hardened working parts give long, reliable, trouble-free life. Cartridge construction for installation into your own manifold.

Sectional View

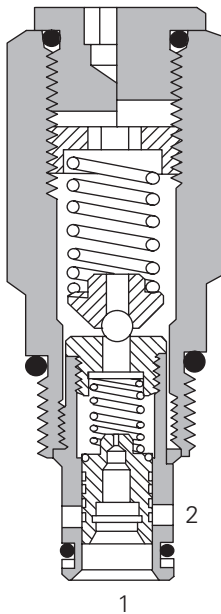

E

Performance Data

Ratings and Specifications

Performance data is typical with fluid at 21,8 cSt (105 SUS) and 49° C (120° F)

Typical application pressure (all ports)	350 bar (5000 psi)
Cartridge fatigue pressure (infinite life)	350 bar (5000 psi)
Rated flow	114 L/min (30 USgpm)
Internal leakage, port 1 to port 2	114 cc/min (7cu in/min @ 350 bar (5000 psi))
Cavity	C-10-2
Standard housing materials	Aluminum or steel
Temperature range	-40° to 120°C (-40° to 248°F)
Fluids	All general purpose hydraulic fluids such as: MIL-H-5606, SAE 10, SAE 20, etc.
Filtration	Cleanliness Code 18/16/13
Weight cartridge only	0,22 kg (0.48 lbs)
Seal kits – RV5	565803 Buna-N 566086 Viton®
– RV5A	565806 Buna-N 889627 Viton®

Viton is a registered trademark of E.I. DuPont

Description

Pressure Override Curves

Cartridge only

Tank pressure = 0

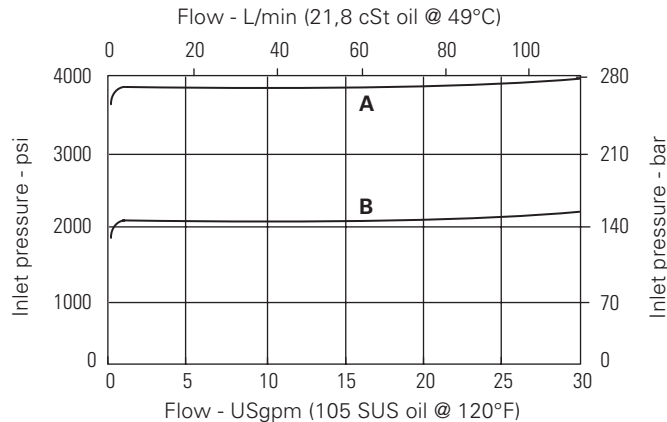

RV5-10 - Relief Valve

Spool, pilot operated

114 L/min (30 USgpm) • 350 bar (5000 psi)

Model Code

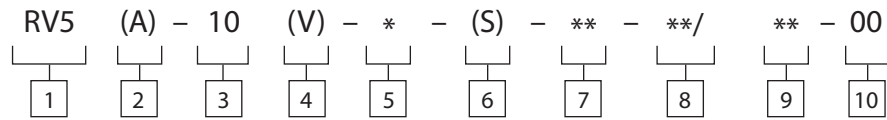

- 1** Function
RV5
Blank
10
Blank
C F I
Blank
- 2** Cage seals
A
KV
K
- 3** Size
Blank
- 4** Seal Material
Blank
- 5** Adjustment
S
- 6** Valve Housing Material
Blank

7 Port Size

Code	Port Size	Housing Number		
		Aluminum Light duty	Aluminum Fatigue rated	Steel Fatigue rated
0	Cartridge only			
3B	3/8" BSPP	02-175462	-	-
2G	1/4" BSPP	-	876702	02-175102
3G	3/8" BSPP	-	876703	02-175103
6H	SAE 6	-	876700	-
8H	SAE 8	-	876701	-
6T	SAE 6	566151	-	02-175100
8T	SAE 8	-	-	02-175101
H10H	SAE 10*	-	4997062-001	-
2K10H	SAE 10**	-	4997060-001	-

* Bolt on, dual cross over relief valve package for Eaton H or T series motors
 ** Bolt on, dual cross over relief valve package for Eaton 2000 series motors
 (Note: Two cartridges are installed in this special housing, both are set to the same crack pressure specified in model code position 9, maximum allowed setting is 210 bar (3000 psi), only available with RV5A option and aluminum housing.)
 See section J for housing details.

- 8** Cracking Pressure Range
 Note: Code based on pressure in psi.
 3 - 3,4-20 bar (50-300 psi)
 20 - 7-140 bar (100-2000 psi)
 35 - 17-240 bar (250-3500 psi)
 50 - 35-350 bar (500-5000 psi)

- 9** Setting pressure
 Within ranges in **8**
 Blank - Normal factory setting at approximate mid-range.
 User requested settings in 3,45 bar (50 psi) steps, Coded as in the following examples:
 10 - 70 bar (1000 psi)
 10.5 - 72,4 bar (1050 psi)

- 10** Special features
 00 - None
 (Only required if valve has special features, omitted if "00.")
 SS - 316 Stainless Steel external components

Dimensions

mm (inch)

Cartridge Only

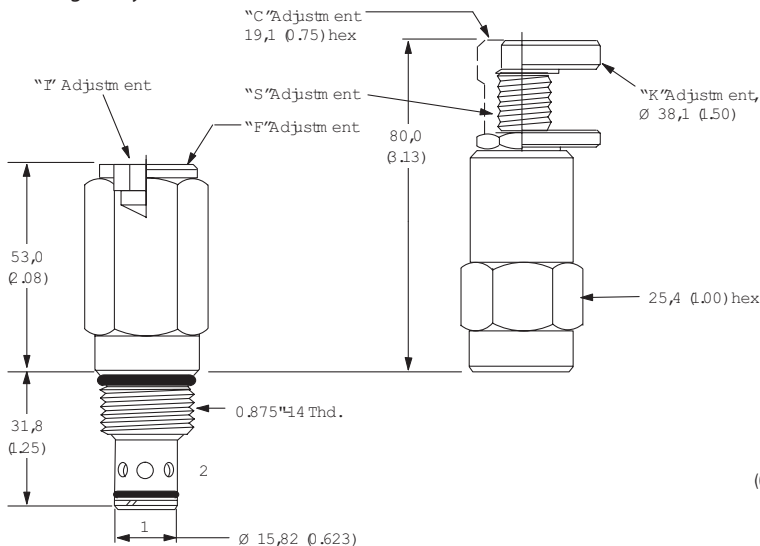

Torque cartridge in housing
 A - 47-54 Nm (35-40 ft. lbs)
 S - 68-75 Nm (50-55 ft. lbs)

Installation Drawing (Steel)

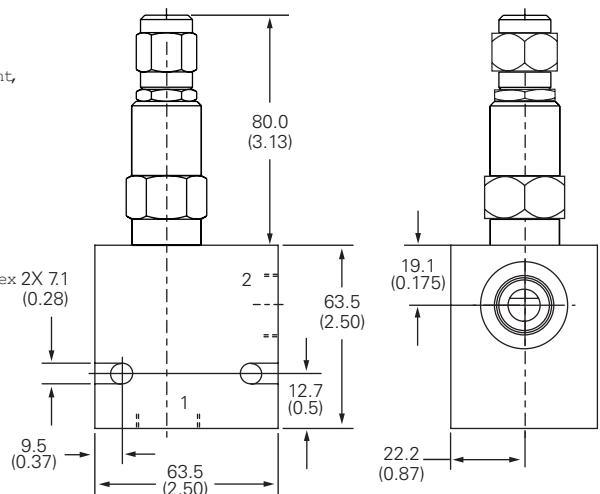

WARNING

Aluminum housings can be used for pressures up to 210 bar (3000 psi). Steel housings must be used for operating pressures above 210 bar (3000 psi).